

MiniProf

Profiling Brake disc wear

The **MiniProf Brake** provides you with an easy and portable tool to monitor your brake discs. Its magnetic attachment enables an easy and flexible mounting on both axle and wheel mounted discs.

The **MiniProf Brake** calculates the disc thickness and wear parameters instantly.

The reliable information on brake wear enables you to optimise your maintenance and safety efforts.

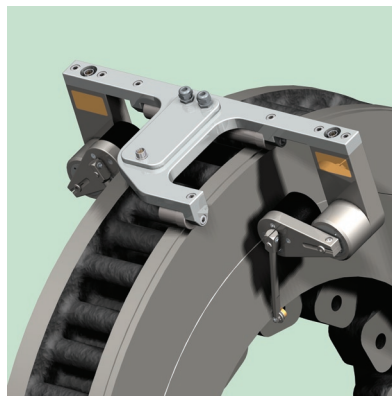

Axle mounted

The axle mounted MiniProf Brake instrument is mounted on the outer diameter of the brake disc and is attached using magnetic rollers. These also align with the small dent on the disc and act as reference points for the measurement.

Measurements of both inner and outer disc side can be combined through the use of measurement schemes enabling an absolute measurement of the disc.

It is possible to measure taper wear, asymmetrical wear and remaining thickness by using both the wheel and the axle mounted unit.

Wheel mounted

A wheel mounted MiniProf Brake instrument is attached to the vertical part of the wheel, either on the backside of the flange or on the outer side of the rim. This part of the wheel is used as a reference for the measurement.

An absolute profile of the disc surface can be found using measurement schemes given the relation between disc and wheel.

Both the axle and wheel mounted units are standard instruments designed for commonly used discs. Please contact Greenwood Engineering for the possibility of adaptation to other disc types.

TwinHead Brake

The MiniProf Brake instruments for axle and wheel mounted discs are single head instruments. With the TwinHead Brake it is now possible to measure both sides of the axle mounted discs.

The TwinHead Brake instrument is placed similar to the axle mounted instrument. The major difference is the two heads that allow both sides of the disc to be measured without moving the instrument. This gives a much more accurate relation between the inner and outer disc sides and enables an even more precise calculation of the brake disc width.

MiniProf features

- Magnetic attachment of instrument
- High precision titanium design
- USB connection to instrument
- Embedded battery for PDA and extended use*
- Shock and water resistant transport case
- Calculation of wear parameters
- Comparison with reference profiles
- Open ASCII file format
- 500-800 points per profile

*) Battery is optional and only available on USB type instruments

Note: MiniProf is patented under the following patent numbers: 166972 in Denmark, 0569469 in Europe, 3154332 in Japan and 5351411 in USA. The European patent covers the following countries: Austria, Belgium, Switzerland/Liechtenstein, Germany, Spain, France, Great Britain, Italy, The Netherlands and Sweden.

Specifications

- Accuracy Better than $\pm 54 \mu\text{m}$
- Repeatability $\pm 20 \mu\text{m}$
- Weight 0.8 kg
- Speed
 - Measuring rate 10000 points/sec.
 - Profile scanning <5 sec.
 - Processing <1 sec.*
- Profile file size 20-30 kb/profile**
- Power consumption
 - Standby 0.5 mA
 - In use 110 mA

*) Processing speed depends on computer. Especially PDA's will be slower.

**) Size depends on configuration and optional compression

Related products



MiniProf Wheel



MiniProf Rail



Brake Extensions

Contact information:

Greenwood Engineering A/S
H. J. Holst Vej 3-5C
DK-2605 Brøndby, Denmark

Phone : +45 3636 0200
Fax : +45 3636 0001
Web : www.greenwood.dk
E-mail : miniprof@greenwood.dk

Agent / Distributor: